

# Unity S-PPC

## Power Plant Controller Solutions for Energy Storage Systems

---

New energy storage technologies have recently experienced increasing penetration in the renewable/electricity market. Excess energy can now be stored cost-efficiently via storage systems, and can thus respond to on-demand energy requirements at peak periods, and be used to accurately control generation output to serve grid requirements.

These new energy storage systems reduce the costs for commercial/residential installations, increase revenues for utility-scale power plants, secure the grid operation and power quality, and most importantly prevent unnecessary and costly central investments required.

To respond to the growing demand for control systems for these new systems, Power Factors has developed S-PPC, a Storage-Enabling extension to Power Factors PV Power Plant Controller.



## S-PPC: SOLUTIONS FOR ENERGY STORAGE SYSTEMS

Power Plant Controller for Energy Storage Systems (S-PPC) is our vendor-independent modular solution that complements the core PPC product line. The Power Factors S-PPC complies with any grid code requirements and is scalable for use by a few hundred KW up to hundreds of MW plants. It integrates with any battery technology, battery management system, and inverter model, ensuring the result complies with the grid code requirements and plant-specific needs.

S-PPC also effectively controls the Battery Management System (BMS) and the Storage Inverters, coordinating the Storage controls with the PV Plant active power control and reactive power compensation resources (inverter, capacitors, etc.).

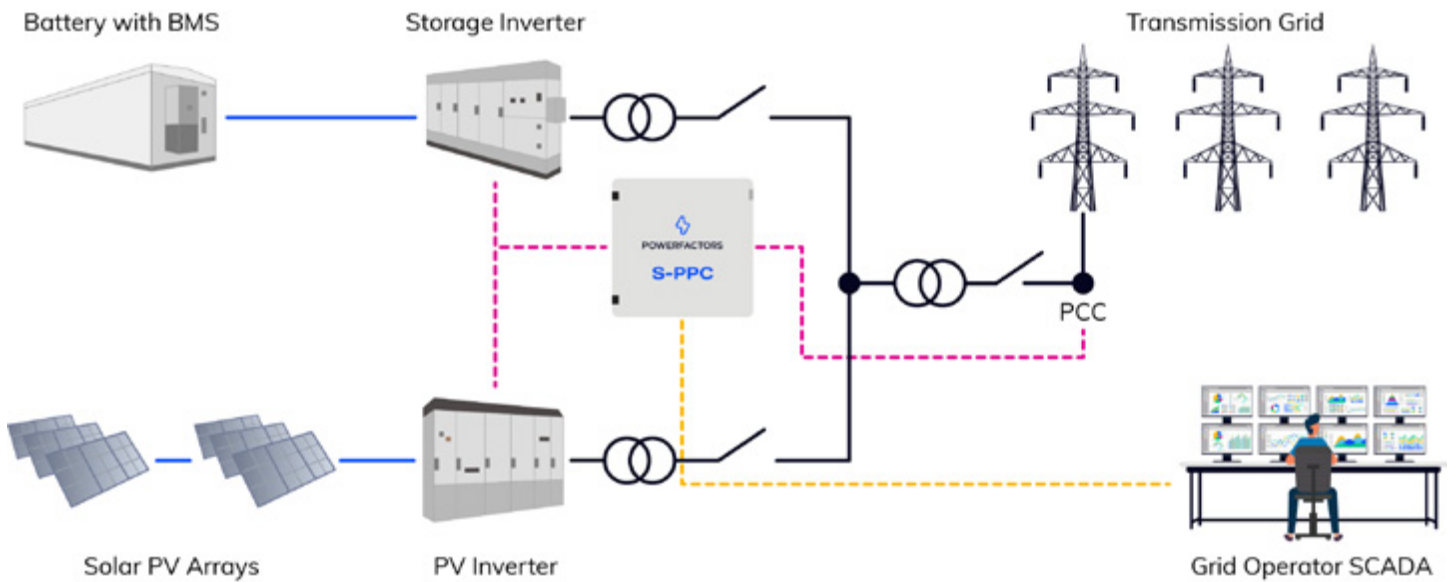

Figure 1 - PV Plant with S-PPC for Energy Storage Systems

S-PPC maximizes revenues and reduces costs for the plant owner by executing control functionality with Frequency Regulation, Peak Shaving, Spinning Reserve, Ramp Rate Control and Capacity Firming, while always complying with grid code requirements.

# ENERGY STORAGE APPLICATIONS

Storage technologies significantly benefit the grid operator and plant owner for commercial and utility-scale applications. S-PPC fully complies with all energy storage schemes, coordinating all plant assets and use scenarios.

## FREQUENCY SUPPORT

Frequency regulation is one of the most critical ancillary services for grid management. Frequency support is provided by ramping up or down the generation assets, for underfrequency or overfrequency events. Using the storage systems, the PPC can coordinate the frequency support in parallel with other plant generators. Response time is several msec while the coordination is performed in 1 sec.

## PEAK SHAVING / ENERGY TIME SHIFTING

In plants with Export Limitation, S-PPC can maximize generation by charging batteries when excess power is not required / curtailed and discharging in periods of low power generation. For commercial installations, PPC with storage can balance generation and consumption curves minimizing consumption. In ToU or Demand-based pricing schemes, the control system can minimize consumption in peak periods.

## CAPACITY FIRING AND ACTIVE POWER CONTROL

Now, Owners/Operators can transform PV plants into dispatchable assets. Using the energy stored, S-PPC can secure the availability of PV plant power thus enabling the operator to bid firm capacity into merchant markets, bypassing its intermittent nature. PV generation is now a dispatchable revenue generating asset which depending on the available market can translate to higher kWh rates during dispatchable periods.

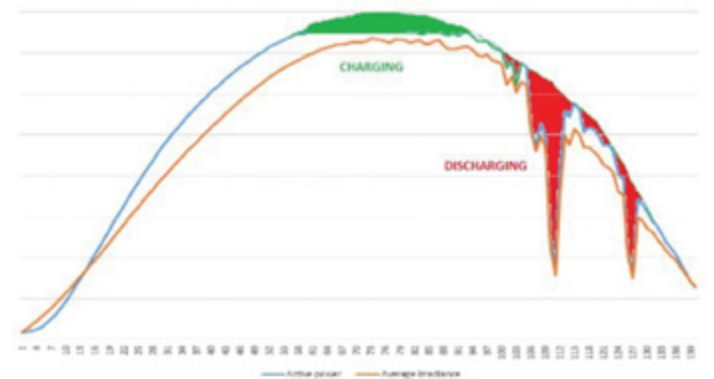

# ENERGY STORAGE APPLICATIONS

## RENEWABLE INTEGRATION RAMP RATES

S-PPC can monitor the PV Plant output and regulate ramp-up/down rates according to grid requirements. Furthermore, with storage-supported ramp-up rate control, the energy that would be lost when a PV inverter enforced the ramp rate limitations (standard industry practice) internally can now be stored.

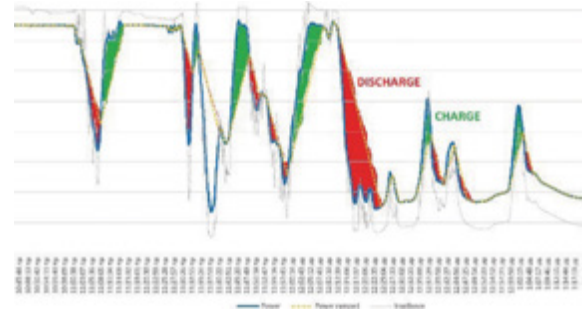

## SPINNING RESERVE

Storage systems provide a Spinning Reserve resource avoiding the respective generator losses for a power plant. Spinning Reserve refers to a Generation capacity that is on standby and that can respond within 10 minutes to compensate for generation or transmission outages. Frequency- response reserves respond within 10 seconds to maintain system frequency. This means that system generators must have a share of immediate reserve capacity associated with their primary energy sources, wasting energy if not stored as in the case of storage systems.

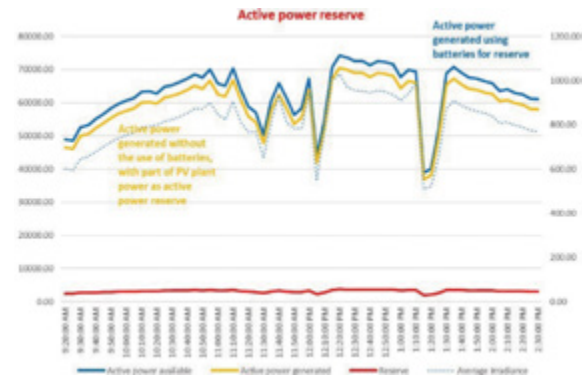

## INTEGRATED ENERGY AND POWER MONITORING

S-PPC is fully interoperable with Power Factors or 3rd party SCADA systems, delivering end-to-end Energy Storage Monitoring, as well as full Plant and Loads monitoring.

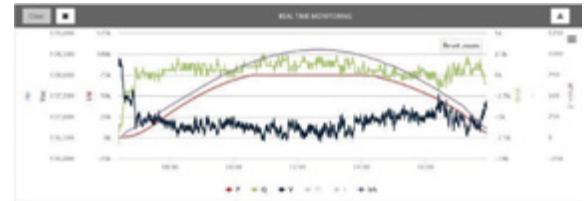

## BENEFITS FOR PLANT OWNERS AND GRID OPERATORS

### For Grid Operators

PV plants become dispatchable assets - the grid can consider them fully responsive and not intermittent by nature.

Capacity of backup resources can be reduced while still securing supply security.

Securing power quality with less transmission infrastructure investments.

Distribution grids are stabilized and relieved from heavy energy shifting.

Energy self-consumption on-site can significantly be increased.

### For Plant Owners

PV plants become dispatchable - the plant can participate in bids it could not address so far.

Maximize energy generation, minimize curtailment losses of solar resource.

Maximize profit, selling energy at the most profitable price.

Fully compensate consumption in zero export scenarios.

Full grid integration with ramp rates, 4-Q reactive power control.